

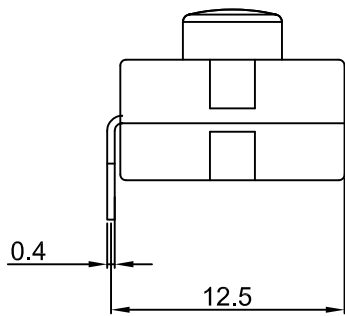

TS202

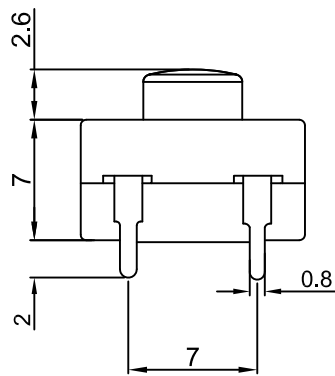
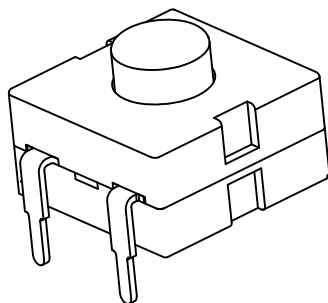
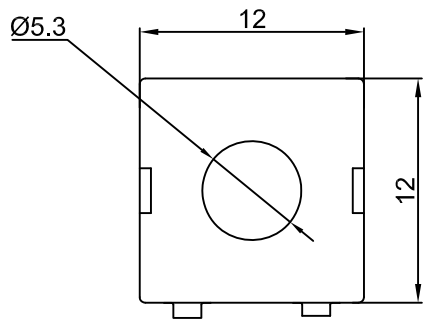

SPECIFICATIONS:

- Rating: DC30V 1A ;
- Contact resistance: 100m Ω (Max.) ;
- Insulation resistance: DC500V 100M Ω (Min.) ;
- Withstand voltage: AC 1000V for 1 minute ;
- Operating force: 700±150g ;
- Life cycle: 20,000 cycles ;
- Total Travel: 1.5±0.3 mm .

MATERIAL:

- Frame:Nylon66,UL rated:94V-2 Min. ;
- Cap:POM ;
- Terminal:Brass,Silver or Tin plated .

Function:

ON(6-1)-OFF

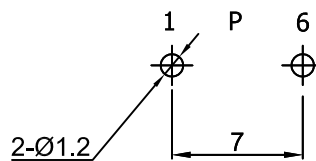

P.C.B. LAYOUT

X	Cap Color
R	Red 红色
Y	Yellow 黄色
G	Green 绿色
B	Black 黑色
U	Blue 蓝色
W	White 白色
A	Gray 灰色

				公差 TOLERANCES		.X± 0.3	.XX± 0.15	角度 ANGLE ± 1°		单位 DIMENSION UNIT	mm.
A1	重新整理发行	2020.07.12	N/A	版本 VERSION	A1	比例尺 SCALE	NONE	日期 DATE	2020.07.12	品名 TITLE	图号 DRAWING NO
A0	New Issue	2008.07.08	N/A	核准		核对	Z.H.B.	绘图		TS202-21-3-R	TS202-21-3-R_A1
版本 VER.	变更说明 CHANGE DESCRIPTION	日期 DATE	ECN NO.	APPROVED BY		CHECKED BY		DRAWN BY			